

Tools

Philips Screwdriver



Allen Key (supplied)



Check List

Familiarise yourself with the contents



Check there is nothing missing



Check you have all the tools required



Make room to assemble the product



Assembly Instructions



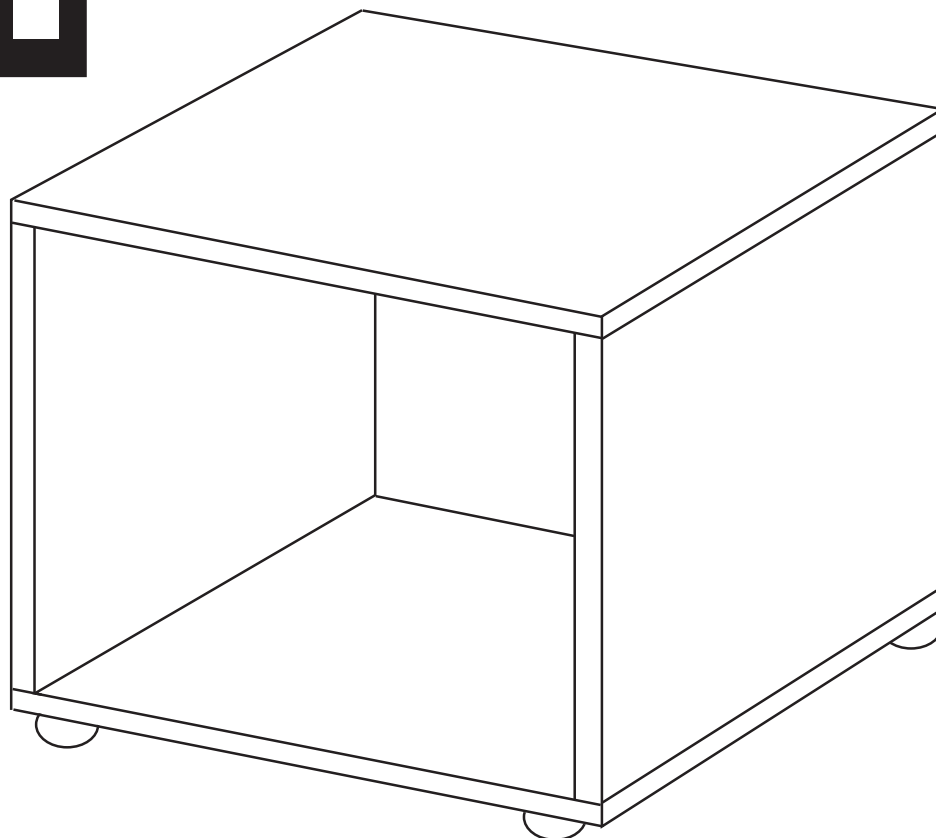

BEECH FILING UNIT

Code: LAMUBH

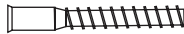

Before starting to assemble this unit please read the step by step assembly instructions carefully.



**Contact Number
0151 479 3030**

Components		Quantity
Confirmat Screws		12
1/2" x 8 Gauge Screw		16
Castor lockable		2
Castor freewheel		2
Allen Key		1
Glue		1

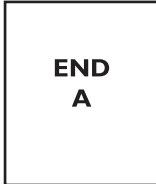
IMPORTANT – Apply a small amount of glue in to the dowel holes before dowels are inserted.

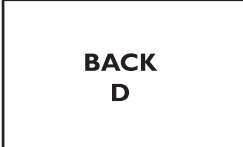
Panels	Quantity	Size (mm)
	2	760x350mm
	1	650x365mm
	1	650x365mm
	1	760x580mm

Contact Number
0151 479 3030

Step 1

Secure castors to bottom using $\frac{1}{2}$ " x 8 Gauge Screws in to "pop" marks (lockable castors for rear).

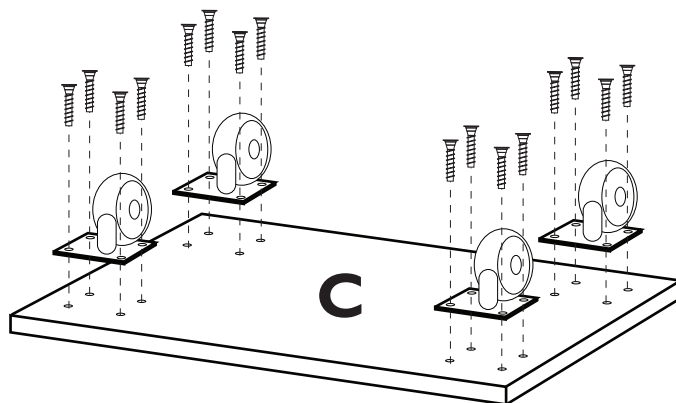

Step 2

Secure bottom C to ends A using Confirmat Screws (lockable castors for floor).

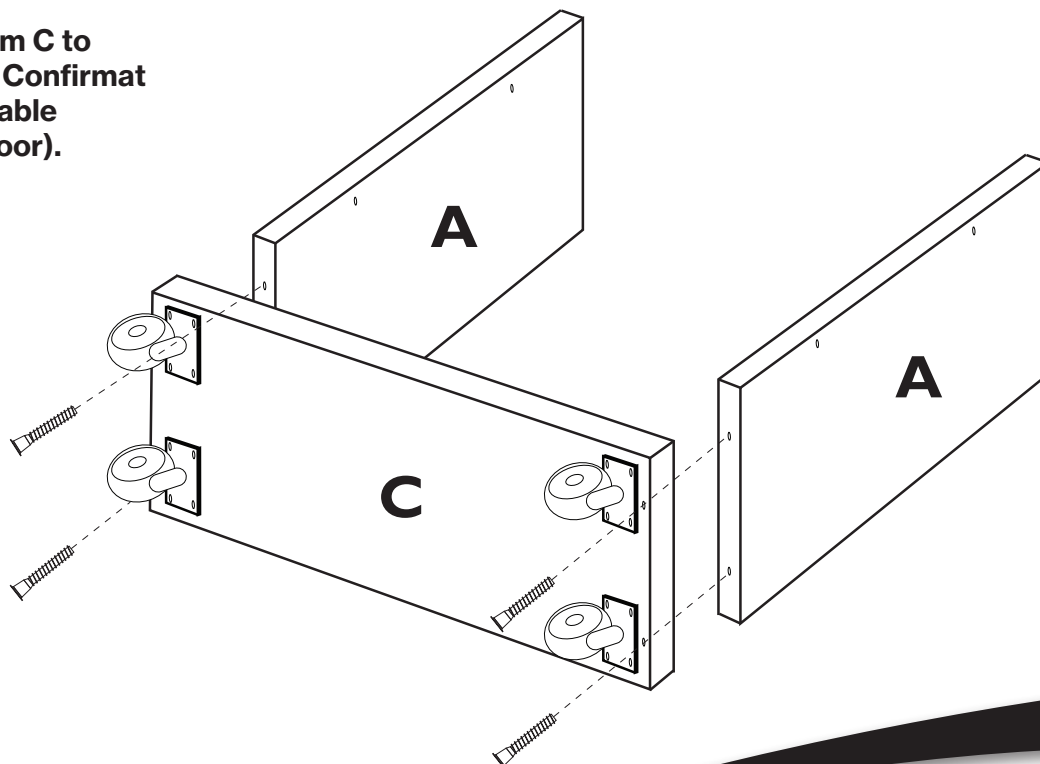

Contact Number
0151 479 3030

Step 3

Secure back to ends
with Cornfirmat Screws.
DO NOT TIGHTEN.

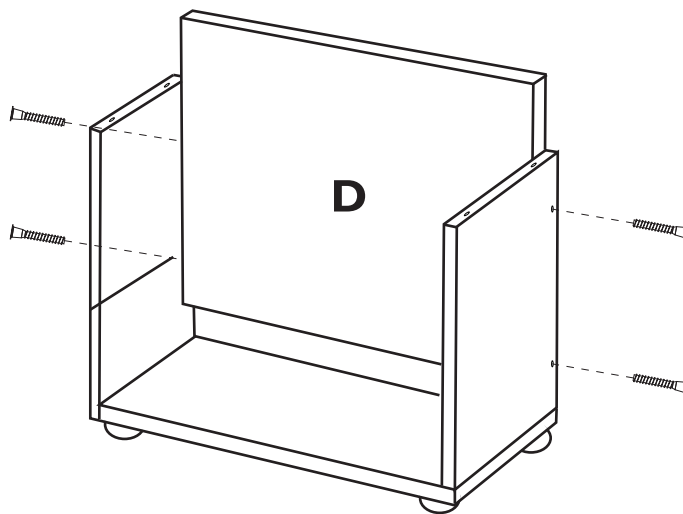

Step 4

Secure top end with
Confirmat Screws.
**DO NOT COMPLETELY
TIGHTEN.**

Assemble filing module
(supplied separately).
Insert in to unit and
**TIGHTEN SCREWS ALL
ROUND.**

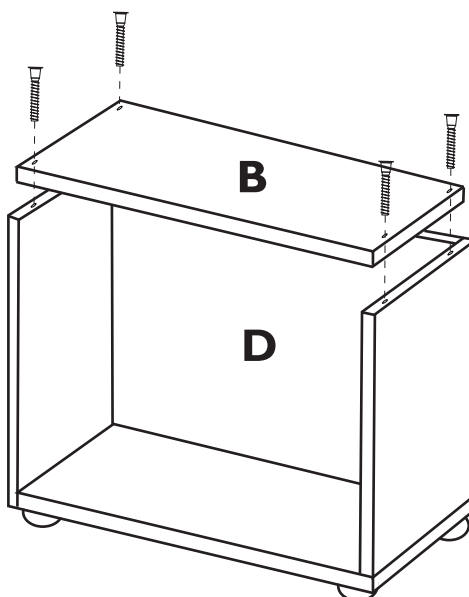

Contact Number
0151 479 3030

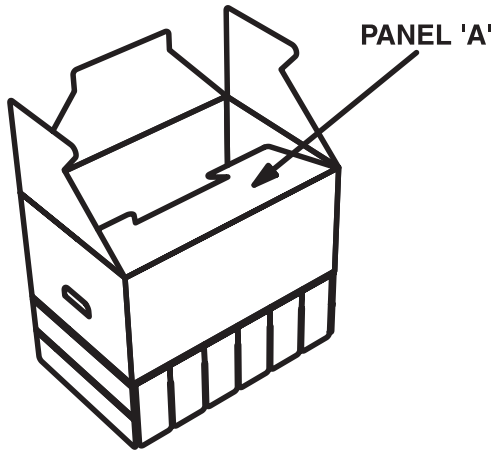

1. Position the carton so the base is accessible from the top. Fold flap 'A' towards the inside of the carton.

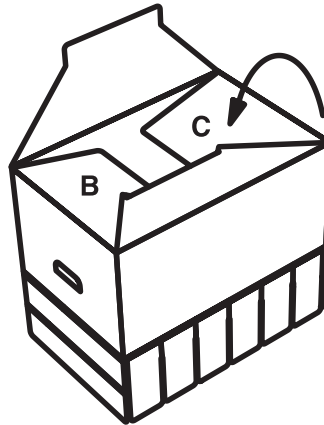

2. Fold flaps 'B' and 'C' over so that they interlock with flap 'A'.

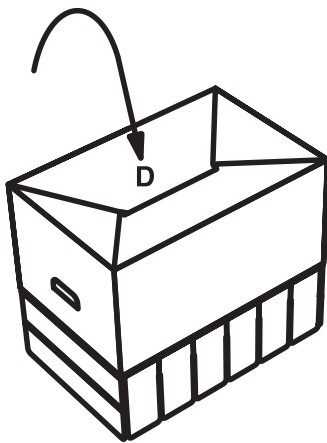

3. Fold Flap 'D' over, this will interlock all base flaps together.

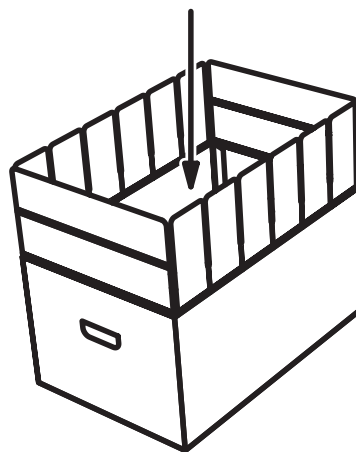

4. Turn carton 180°s and push the base flaps down from inside the carton to form a secure base.

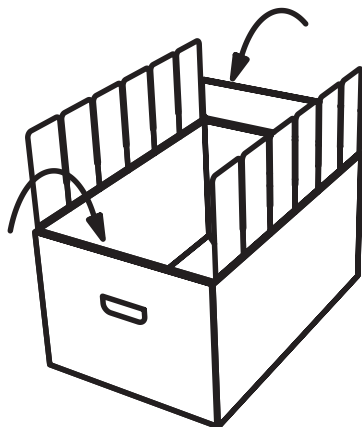

5. Fold over the end panels as shown.

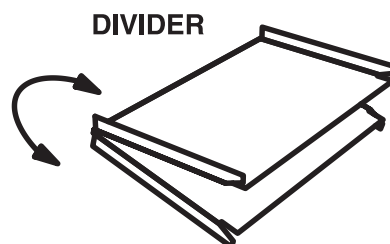

6. Form dividers as shown.

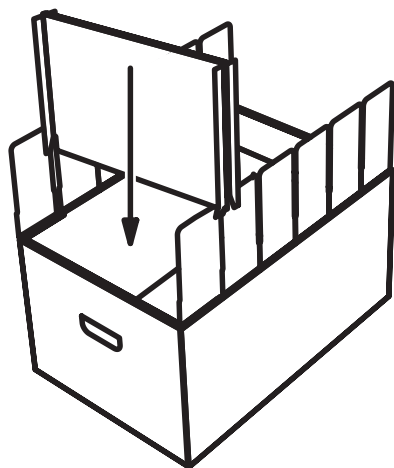

7. Slide the dividers into place as shown.

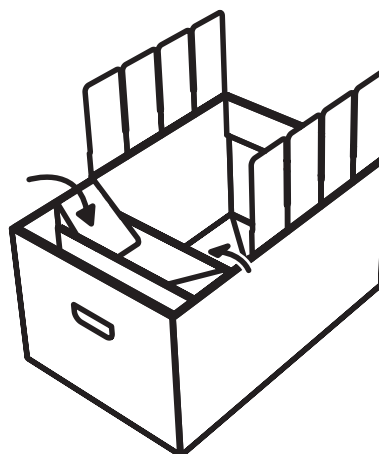

8. Lock dividers into place by folding over each flap. Repeat process on all dividers.