

Outdoor Vision Boards with Stands Assembly Instructions

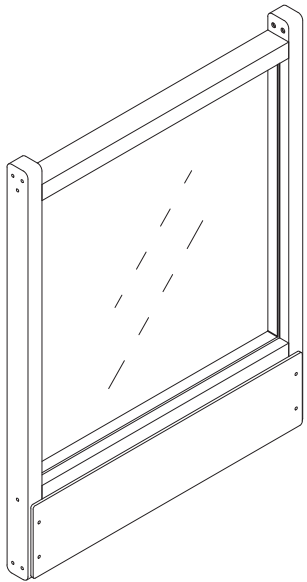

**Item Code:
HW1-S369SET**

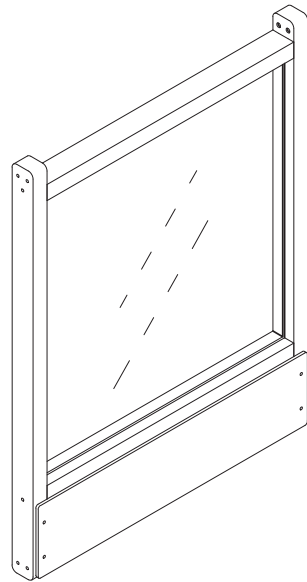

**Item Code:
HW1-S370SET**

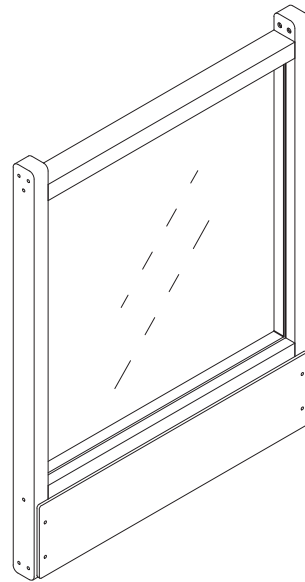

**Item Code:
HW1-S71SET**

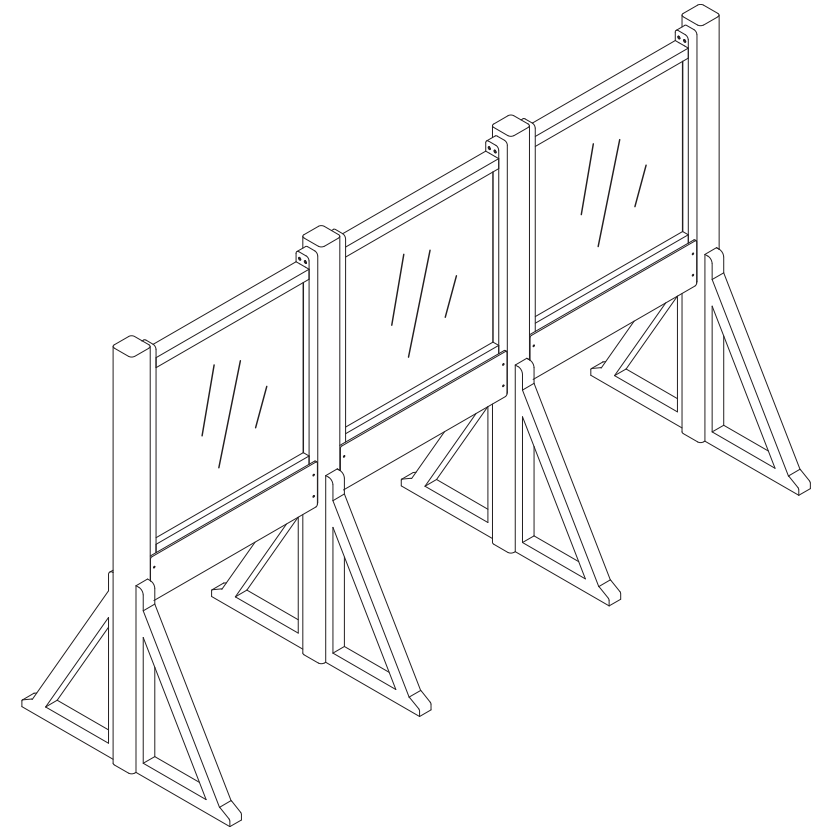

**Item Code:
HW1-SZH02SET (Complete Set)**

Manufacturer: Wisdom Educational Product Co.,Ltd
Manufacturer Address: Building 4, Lane 2777, Baoan Road,
Malu Town, Jiading District, Shanghai, China
Test standard: EN 1176-1:2017

**AN ELECTRIC SCREWDRIVER
IS RECOMMENDED FOR
ASSEMBLY (NOT INCLUDED)**



Outdoor Vision Boards with Stands Assembly Instructions

WARNING

- Contains small parts, sharp points and edges.
- Adult assembly required.
- Two adults recommended.
- Do not stand, sit, kneel, lean or pull on unit for support.
- Never leave children unattended.
- Do not place unit near high heat or moisture.
- Adult supervision recommended.
- Do not allow children to climb on shelves.
- Do not use as a ladder or cart.

TIPS!

1. Do not fully tighten screws until all screws have been loosely positioned.
2. Before assembling, make sure there are no missing parts.

1 YEAR LIMITED WARRANTY

We will supply, without charge, any part discovered to be missing at the time of purchase or found to be defective during the 1-year warranty period. The warranty begins on the date of purchase. We will replace without charge any part found to be missing at the time of purchase, damaged on delivery or defective during the first year of use. This warranty does not cover any damage caused by accident, improper care, negligence, normal wear and tear, surface corrosion on metal parts, discoloured surfaces and other cosmetic issues or failures due to misuse or vandalism. Natural changes in wood over time are considered cosmetic issues and are not covered.

Outdoor Vision Boards with Stands Assembly Instructions

INSTRUCTIONS

1. **Please read the instructions and warning labels carefully before use.**
2. A minimum of two adults are required for assembly.
3. The product and materials are intended for indoor or outdoor use under supervised conditions.
4. Check the quantity of parts based on parts list before assembly.
5. When installing, ensure ground is either a soft fall surface, or protected by a soft material such as cardboard or a blanket when assembling to avoid frame scratching.
6. Tighten all bolts after assembly.
7. Removal all assembly materials and tools from the play area before the equipment is used.
8. During the process of incomplete installation, disassembly, or maintenance, the children should stay away from the product to ensure safety.
9. Inspect items and play area for any potential hazards prior to use.
10. Maximum number of people using the equipment at the same time is 5.
11. User age group: 2-12 years old.
12. Never leave children unattended.
13. Ensure constant adult supervision.
14. Please pay attention to the safety of the surrounding environment before use and avoid use under bad weather conditions.
15. The critical falling height is 0.9m (this is the maximum platform height), and the ground should be covered by protective surfacing materials. The materials should meet the corresponding safety standard EN1177, and the size should not be smaller than the use zone of the product.
16. If the material is damaged and needs to be repaired, please contact the manufacture to repair or replace.

INSTALLATION METHODS

Please ensure that the installation ground is horizontal during installation and keep it horizontal during use.

Method 1: Sand layer, required size in 0.25-2mm, overall depth is not less than 22CM, monthly check to prevent the loss and potential risk.

Method 2: Wood mulch layer, required size in 20-80mm, overall depth is not less than 22CM, monthly check to prevent the loss and potential risk.

Method 3: Wood chip layer, required size in 5-30mm, overall depth is not less than 22CM, monthly check to prevent the loss and potential risk.

Method 4: Pea Gravel layer, required size in 2-8mm, overall depth is not less than 22CM, monthly check to prevent the loss and potential risk.

Method 5: Falling Mat, meet the corresponding safety requirements of EN1177.

MAINTENANCE

1. Use neutral cleaners for cleaning.
2. Clean wood with a damp cloth or sponge using warm water and mild soap. Wipe dry.
3. Regularly inspect the product – check for loose or worn parts periodically and tighten or replace as necessary.
4. Treated pine is designed for outdoor use, this item has been pre-treated with an environmentally friendly preservative which deeply penetrates the wood.
5. A further 2 layers of wood wax oil (also environmentally friendly) are also added for further protection.
6. For maximum product life we would advise to retreat with a further coat of wood wax oil each year.
7. Do not place near heat, moisture or vaporizer which may cause wood to warp and peel.
8. Follow the below inspection cycle to adequately inspect the product.
9. Fill in the inspection record after the inspection.

Outdoor Music Boards with Stands - Item Code: HW1-S369SET

FRONT

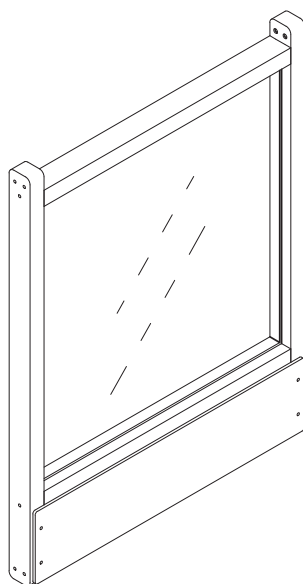

Record the manufacture date here. Information is located on a label enclosed, and on the shipping carton. Place label and this sheet in an accessible place.
Model Number: HW1-S369SET

Manufacture Date: _____

Fasten your Hex Key Tool in the box below and keep in a convenient place for future use.

PART LIST



HARDWARE



DIMENSIONS



Outdoor Music Boards with Stands - Item Code: HW1-S369SET

Step 1

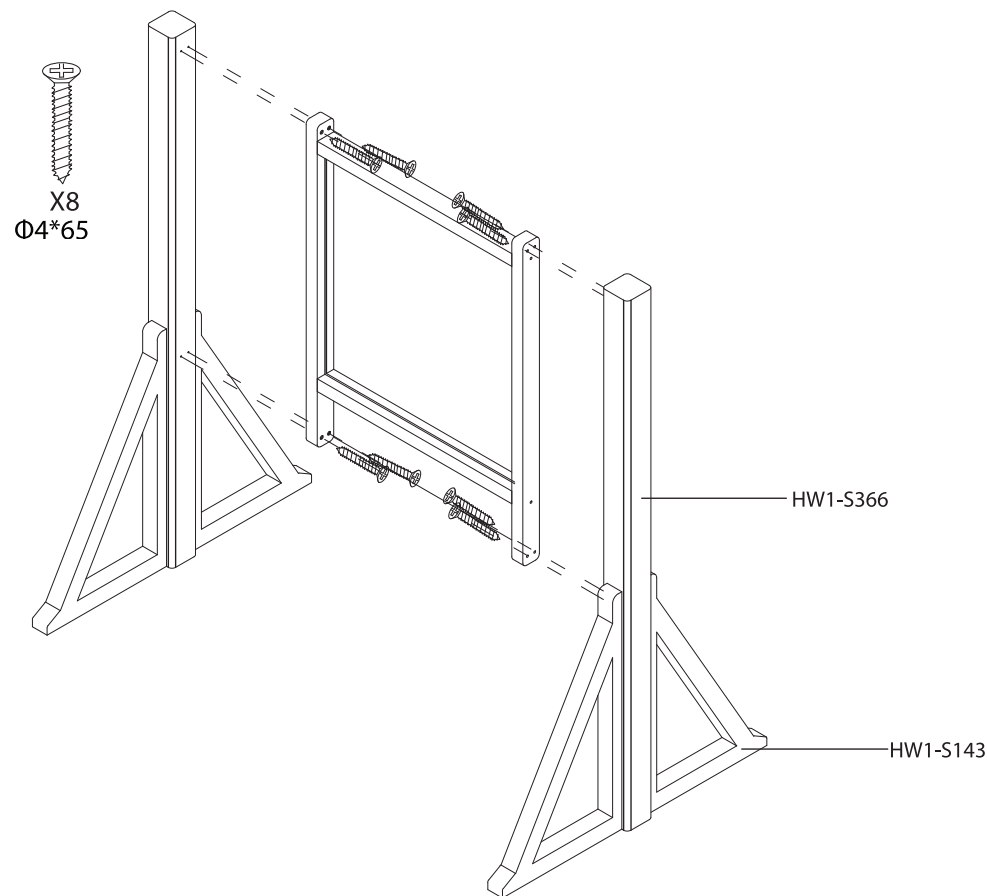

Ensure the area is safe and devoid of any hazards prior to assembly.

The single item is portable and can be used free standing (without ground anchors) – adult supervision advised, if preferred the item can be fixed in place with 1 set of 2 ground anchors for grass/soil base (anchors supplied).

Outdoor Music Boards with Stands - Item Code: HW1-S369SET

Installing Ground Anchors

1. Firstly determine the coordinate points that need to be fixed to the product. With the digging tool, dig 46CM downward the grass, bury the grass anchor, then tamp the soil.
2. Fixed the product on a suitable position, use the fabric loop to hook the grass anchor and fix the fabric loop to the suitable position with M4*25 tapping screws to complete the installation.

The ground anchor should be buried under the horizontal line as photo indicated. To easily get the ground anchor into the ground, simply insert the pointed end into the ground - these anchors are called screw in anchors. The round disc ensures that you have a lot of grip in the ground so that the anchor can easily be screwed deep into the ground. It is best to use a screwdriver (or small metal bar) or other long object about 5-6 millimetres thick to rotate the anchor. You push this through the ring, which is attached to the top, after which you simply turn the anchor around and drill into the ground. Make sure to leave about 6 to 7 cm above the ground at the top so that you have enough room to attach the ground anchor to the post.

Then place the supplied screw through the ring and drill it to the post.

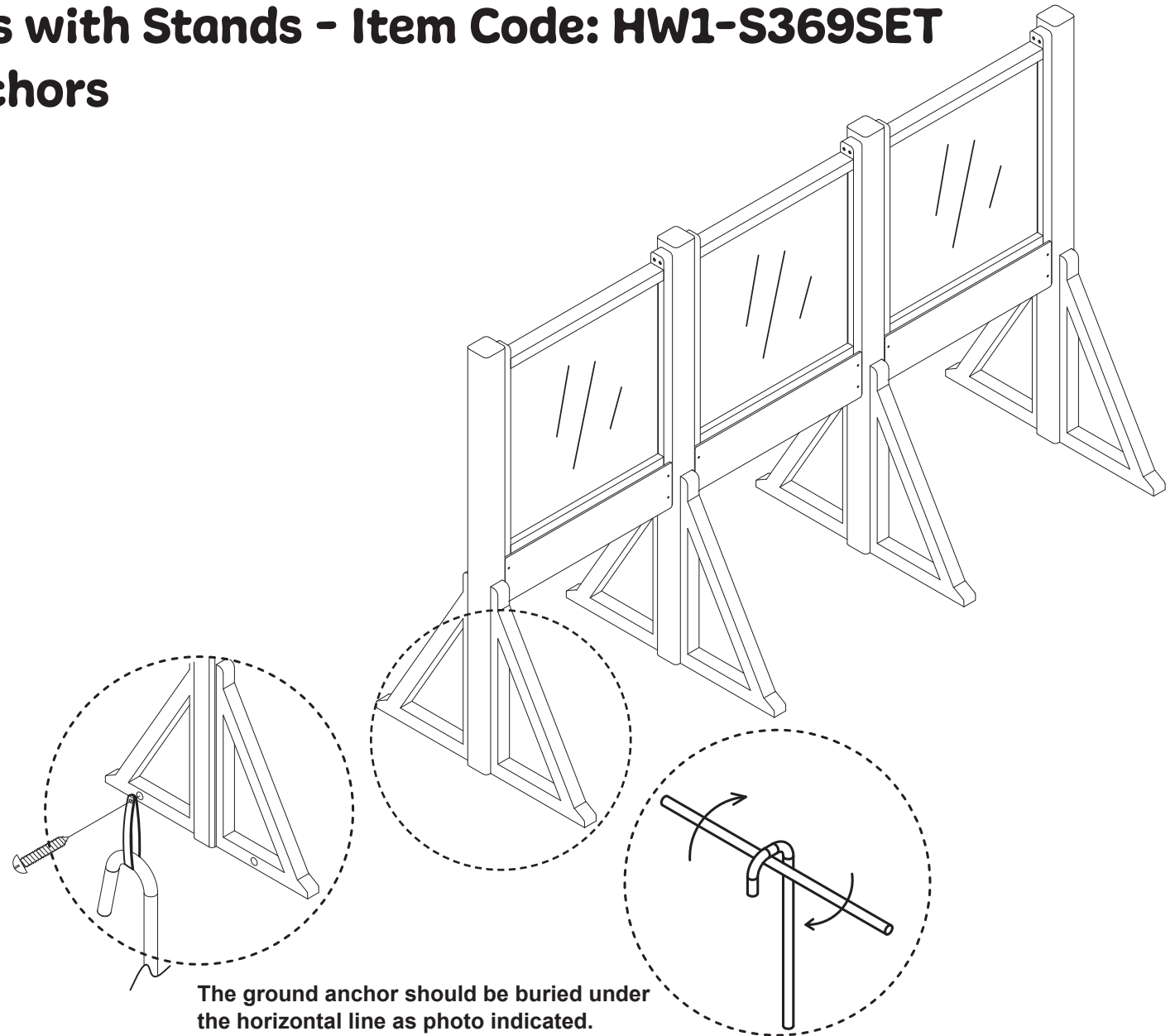

The ground anchor should be buried under the horizontal line as photo indicated.

Outdoor Music Boards with Stands - Item Code: HW1-S369SET

INSPECTION INFORMATION				
Inspection cycle	Inspection Project	YES/NO	Solution	Signature
Daily Inspection on Items	Check screws, bolts and fasteners are tightened.			
	Installed on a flat surface and no hazards are present.			
	Equipment is free of dirt and moisture.			
	Hook and loop attachments are securely fastened.			
	Check for a signs of damage and wear.			
Monthly Inspection on Items (Except for Daily Inspection on Items)	Check screws are free of rust and damage.			
	Check parts are securely connected.			
	Check compliance labels are intact.			
	Check if the protective surfacing meet safety standards			
Annual Inspection on Items (Except for Daily and Monthly Inspection on Items)	Check there is no extensive corrosion and replace if required.			
	Check for cracking or connecting part deterioration. Replace if required.			
	Check there is no excessive discolouration of components.			
	Check screws and connectors are in working order and not damaged or deteriorated.			
	Check compliance labels are legible.			
	Check the play area under the equipment is safe and level.			

Outdoor Music Boards with Stands - Item Code: HW1-S370SET

FRONT

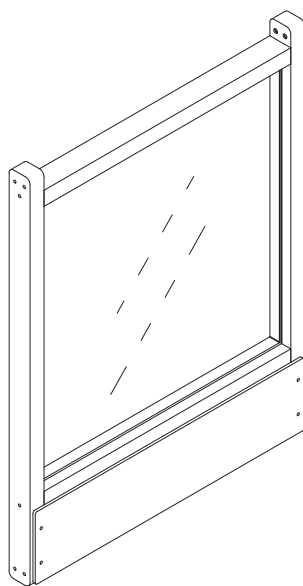

Record the manufacture date here. Information is located on a label enclosed, and on the shipping carton. Place label and this sheet in an accessible place.
Model Number: HW1-S370SET

Manufacture Date: _____

Fasten your Hex Key Tool in the box below and keep in a convenient place for future use.

PART LIST



HARDWARE



DIMENSIONS



Outdoor Music Boards with Stands - Item Code: HW1-S370SET

Step 1

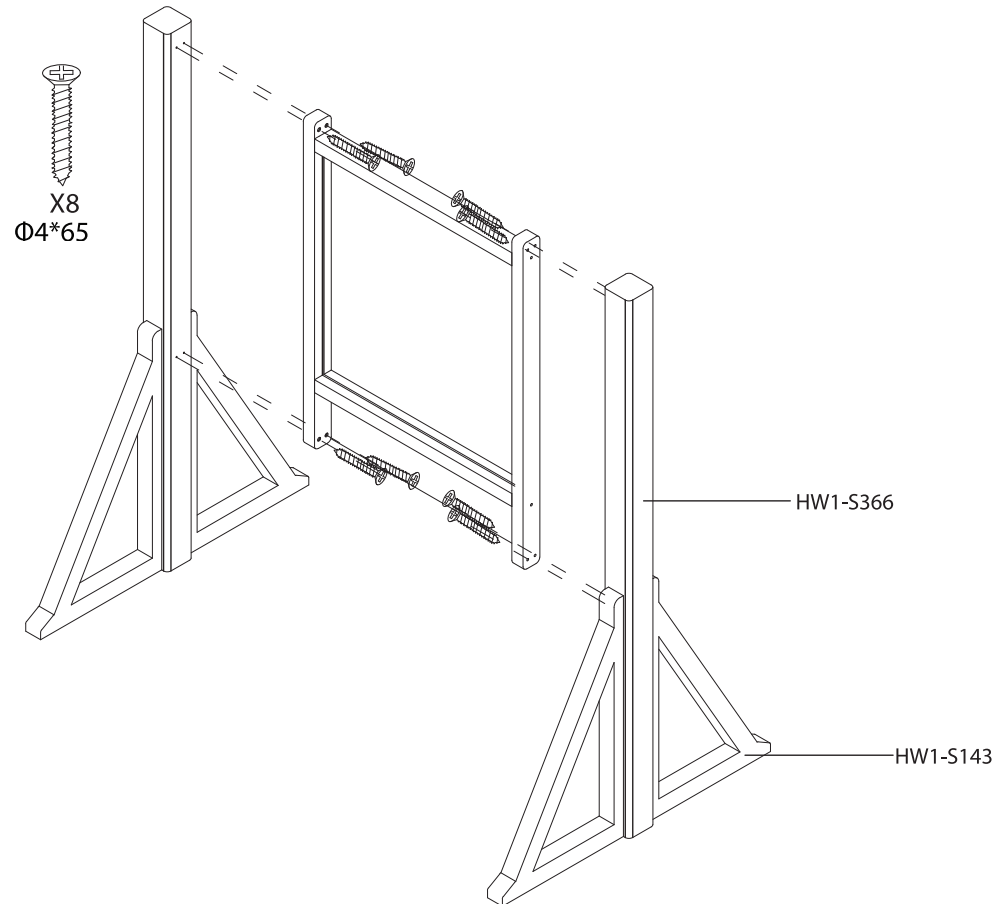

Ensure the area is safe and devoid of any hazards prior to assembly.

The single item is portable and can be used free standing (without ground anchors) – adult supervision advised, if preferred the item can be fixed in place with 1 set of 2 ground anchors for grass/soil base (anchors supplied).

Outdoor Music Boards with Stands - Item Code: HW1-S370SET

Installing Ground Anchors

1. Firstly determine the coordinate points that need to be fixed to the product. With the digging tool, dig 46CM downward the grass, bury the grass anchor, then tamp the soil.
2. Fixed the product on a suitable position, use the fabric loop to hook the grass anchor and fix the fabric loop to the suitable position with M4*25 tapping screws to complete the installation.

The ground anchor should be buried under the horizontal line as photo indicated. To easily get the ground anchor into the ground, simply insert the pointed end into the ground - these anchors are called screw in anchors. The round disc ensures that you have a lot of grip in the ground so that the anchor can easily be screwed deep into the ground. It is best to use a screwdriver (or small metal bar) or other long object about 5-6 millimetres thick to rotate the anchor. You push this through the ring, which is attached to the top, after which you simply turn the anchor around and drill into the ground. Make sure to leave about 6 to 7 cm above the ground at the top so that you have enough room to attach the ground anchor to the post.

Then place the supplied screw through the ring and drill it to the post.

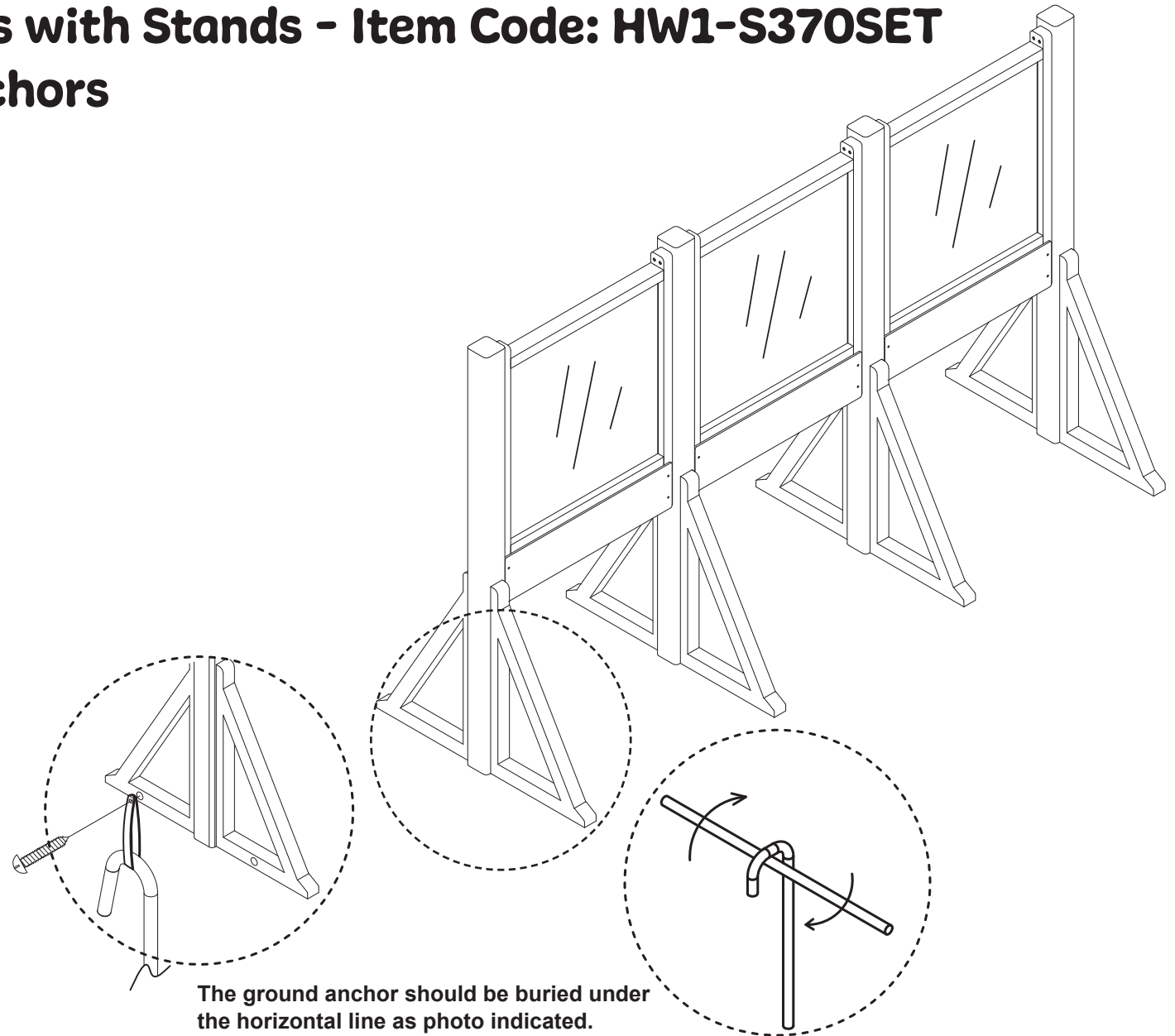

Outdoor Music Boards with Stands - Item Code: HW1-S370SET

INSPECTION INFORMATION				
Inspection cycle	Inspection Project	YES/NO	Solution	Signature
Daily Inspection on Items	Check screws, bolts and fasteners are tightened.			
	Installed on a flat surface and no hazards are present.			
	Equipment is free of dirt and moisture.			
	Hook and loop attachments are securely fastened.			
	Check for a signs of damage and wear.			
Monthly Inspection on Items (Except for Daily Inspection on Items)	Check screws are free of rust and damage.			
	Check parts are securely connected.			
	Check compliance labels are intact.			
	Check if the protective surfacing meet safety standards			
Annual Inspection on Items (Except for Daily and Monthly Inspection on Items)	Check there is no extensive corrosion and replace if required.			
	Check for cracking or connecting part deterioration. Replace if required.			
	Check there is no excessive discolouration of components.			
	Check screws and connectors are in working order and not damaged or deteriorated.			
	Check compliance labels are legible.			
	Check the play area under the equipment is safe and level.			

Outdoor Music Boards with Stands - Item Code: HW1-S371SET

FRONT

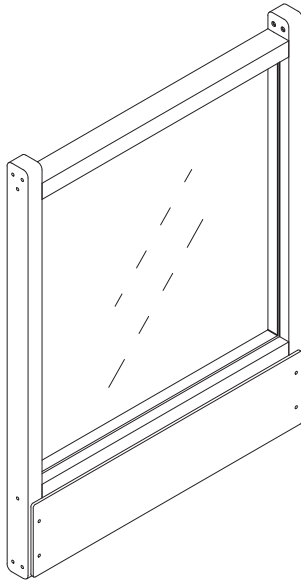

Record the manufacture date here. Information is located on a label enclosed, and on the shipping carton. Place label and this sheet in an accessible place.
Model Number: HW1-S371SET

Manufacture Date: _____

Fasten your Hex Key Tool in the box below and keep in a convenient place for future use.

PART LIST



HARDWARE



DIMENSIONS



Outdoor Music Boards with Stands - Item Code: HW1-S371SET

Step 1

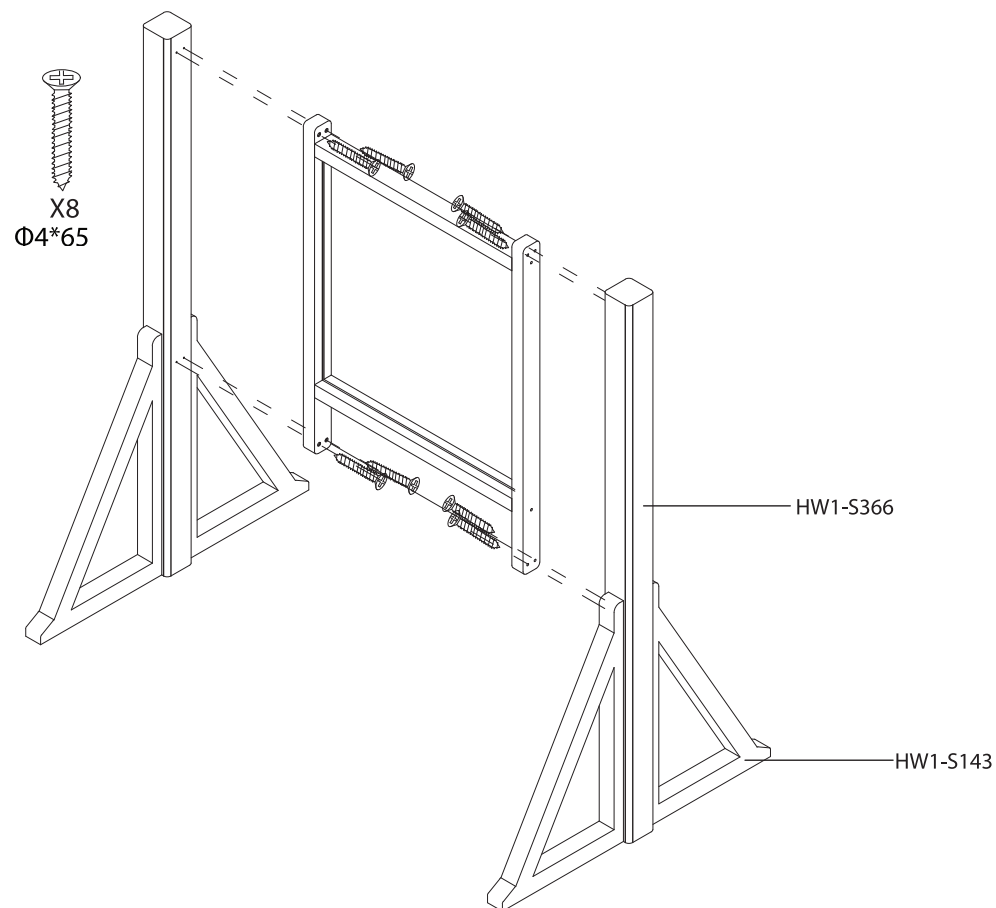

Ensure the area is safe and devoid of any hazards prior to assembly.

The single item is portable and can be used free standing (without ground anchors) – adult supervision advised, if preferred the item can be fixed in place with 1 set of 2 ground anchors for grass/soil base (anchors supplied).

Outdoor Music Boards with Stands - Item Code: HW1-S371SET

Installing Ground Anchors

1. Firstly determine the coordinate points that need to be fixed to the product. With the digging tool, dig 46CM downward the grass, bury the grass anchor, then tamp the soil.
2. Fixed the product on a suitable position, use the fabric loop to hook the grass anchor and fix the fabric loop to the suitable position with M4*25 tapping screws to complete the installation.

The ground anchor should be buried under the horizontal line as photo indicated. To easily get the ground anchor into the ground, simply insert the pointed end into the ground - these anchors are called screw in anchors. The round disc ensures that you have a lot of grip in the ground so that the anchor can easily be screwed deep into the ground. It is best to use a screwdriver (or small metal bar) or other long object about 5-6 millimetres thick to rotate the anchor. You push this through the ring, which is attached to the top, after which you simply turn the anchor around and drill into the ground. Make sure to leave about 6 to 7 cm above the ground at the top so that you have enough room to attach the ground anchor to the post.

Then place the supplied screw through the ring and drill it to the post.

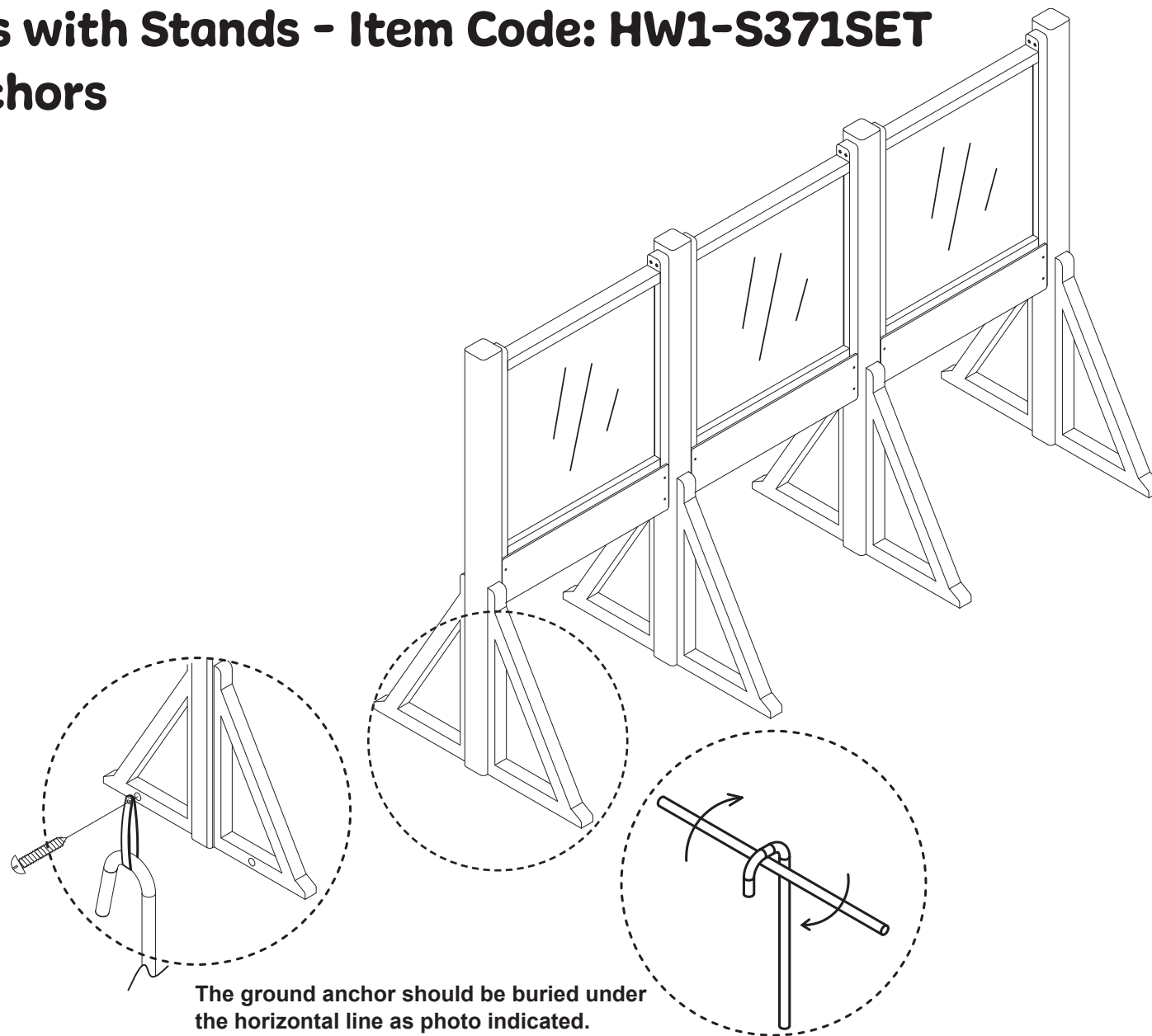

Outdoor Music Boards with Stands - Item Code: HW1-S371SET

INSPECTION INFORMATION				
Inspection cycle	Inspection Project	YES/NO	Solution	Signature
Daily Inspection on Items	Check screws, bolts and fasteners are tightened.			
	Installed on a flat surface and no hazards are present.			
	Equipment is free of dirt and moisture.			
	Hook and loop attachments are securely fastened.			
	Check for a signs of damage and wear.			
Monthly Inspection on Items (Except for Daily Inspection on Items)	Check screws are free of rust and damage.			
	Check parts are securely connected.			
	Check compliance labels are intact.			
	Check if the protective surfacing meet safety standards			
Annual Inspection on Items (Except for Daily and Monthly Inspection on Items)	Check there is no extensive corrosion and replace if required.			
	Check for cracking or connecting part deterioration. Replace if required.			
	Check there is no excessive discolouration of components.			
	Check screws and connectors are in working order and not damaged or deteriorated.			
	Check compliance labels are legible.			
	Check the play area under the equipment is safe and level.			

Outdoor Vision Boards with Stands - Item Code: HW1-SZH02SET (Complete Set)

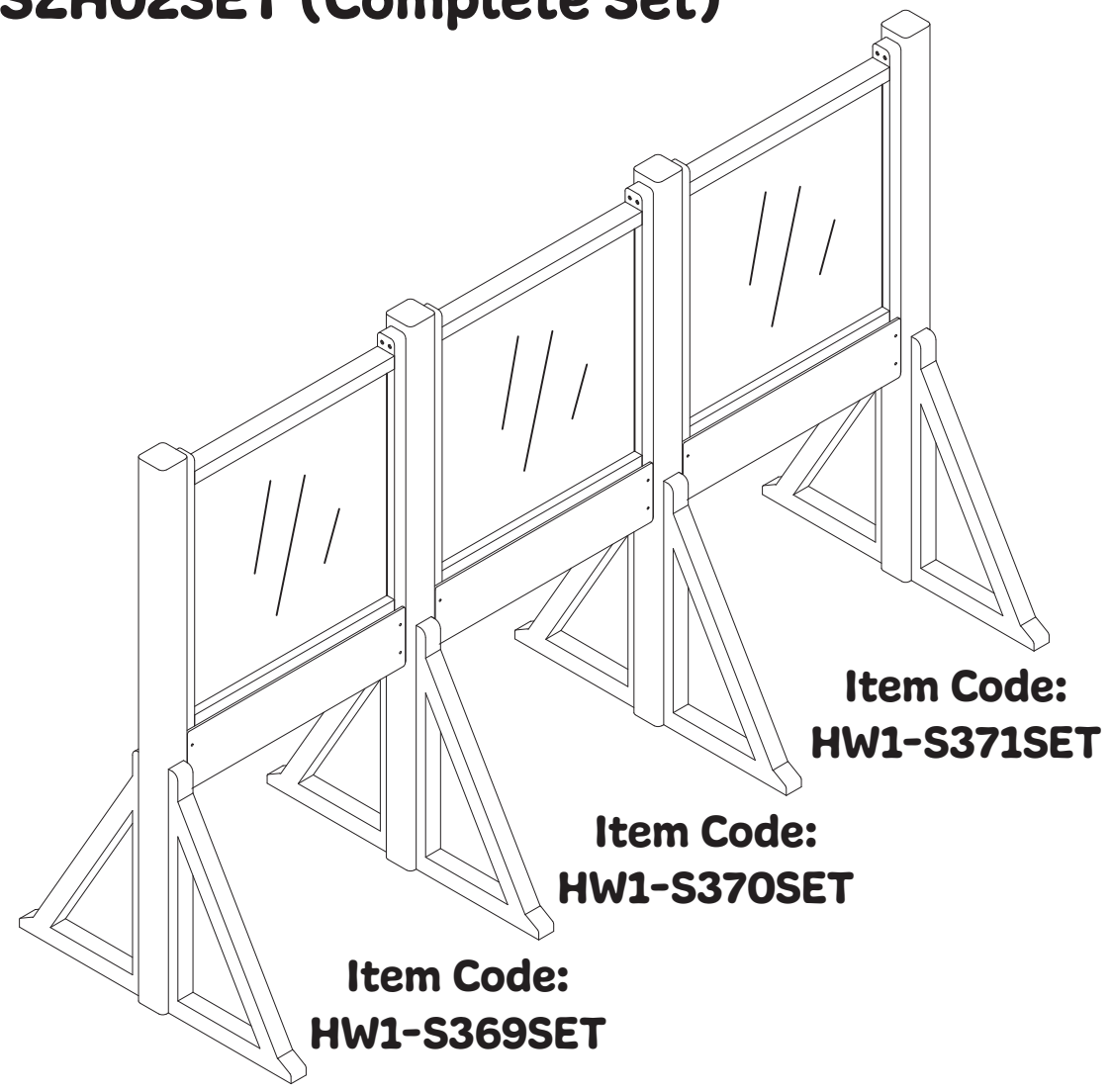

Outdoor Vision Boards with Stands - Item Code: HW1-SZH02SET (Complete Set)

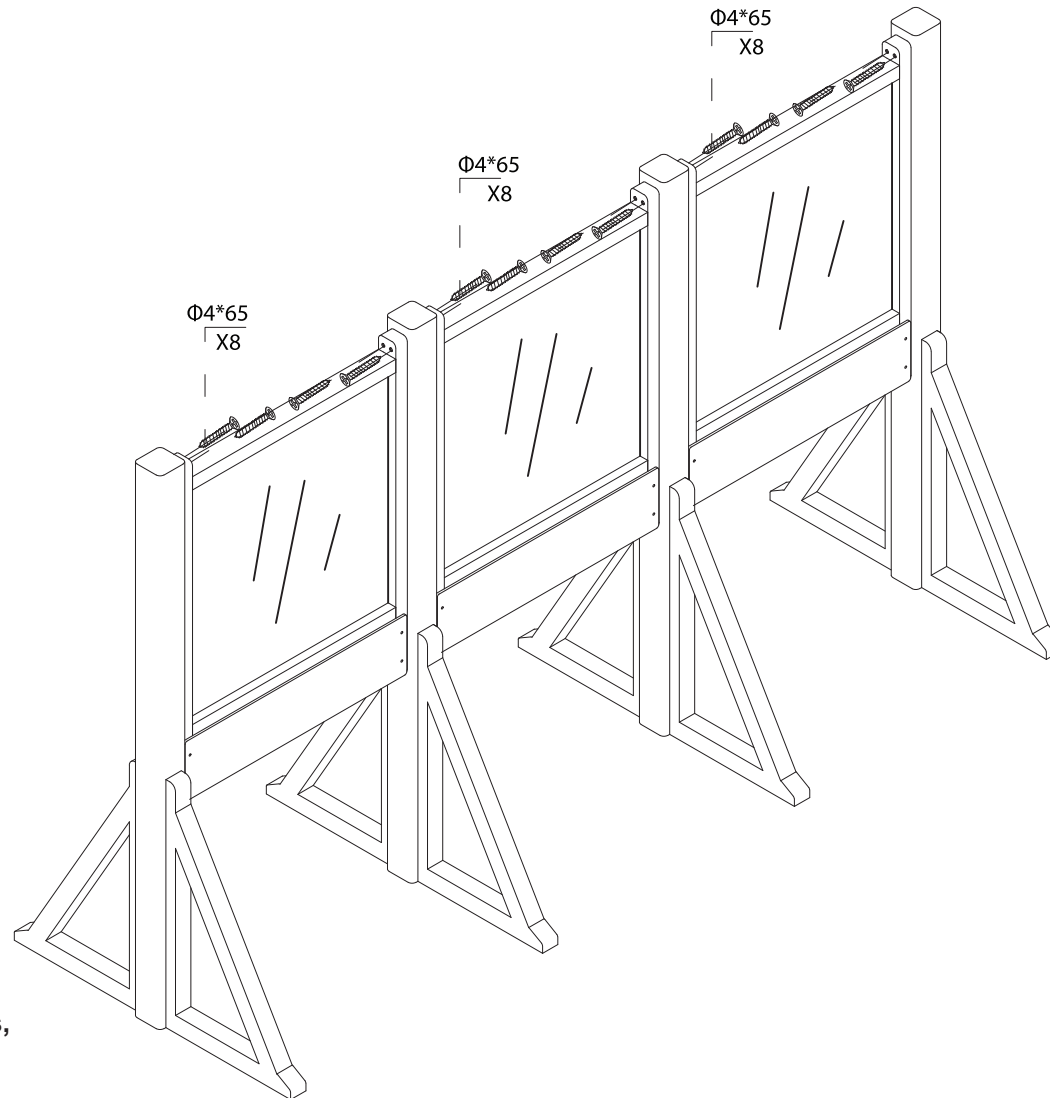

When assembled with other products,
it shares one column.

Outdoor Vision Boards with Stands - Item Code: HW1-SZH02SET (Complete Set) Installing Ground Anchors

1. Firstly determine the coordinate points that need to be fixed to the product. With the digging tool, dig 46CM downward the grass, bury the grass anchor, then tamp the soil.
2. Fixed the product on a suitable position, use the fabric loop to hook the grass anchor and fix the fabric loop to the suitable position with M4*25 tapping screws to complete the installation.

The ground anchor should be buried under the horizontal line as photo indicated. To easily get the ground anchor into the ground, simply insert the pointed end into the ground - these anchors are called screw in anchors. The round disc ensures that you have a lot of grip in the ground so that the anchor can easily be screwed deep into the ground. It is best to use a screwdriver (or small metal bar) or other long object about 5-6 millimetres thick to rotate the anchor. You push this through the ring, which is attached to the top, after which you simply turn the anchor around and drill into the ground. Make sure to leave about 6 to 7 cm above the ground at the top so that you have enough room to attach the ground anchor to the post.

Then place the supplied screw through the ring and drill it to the post.

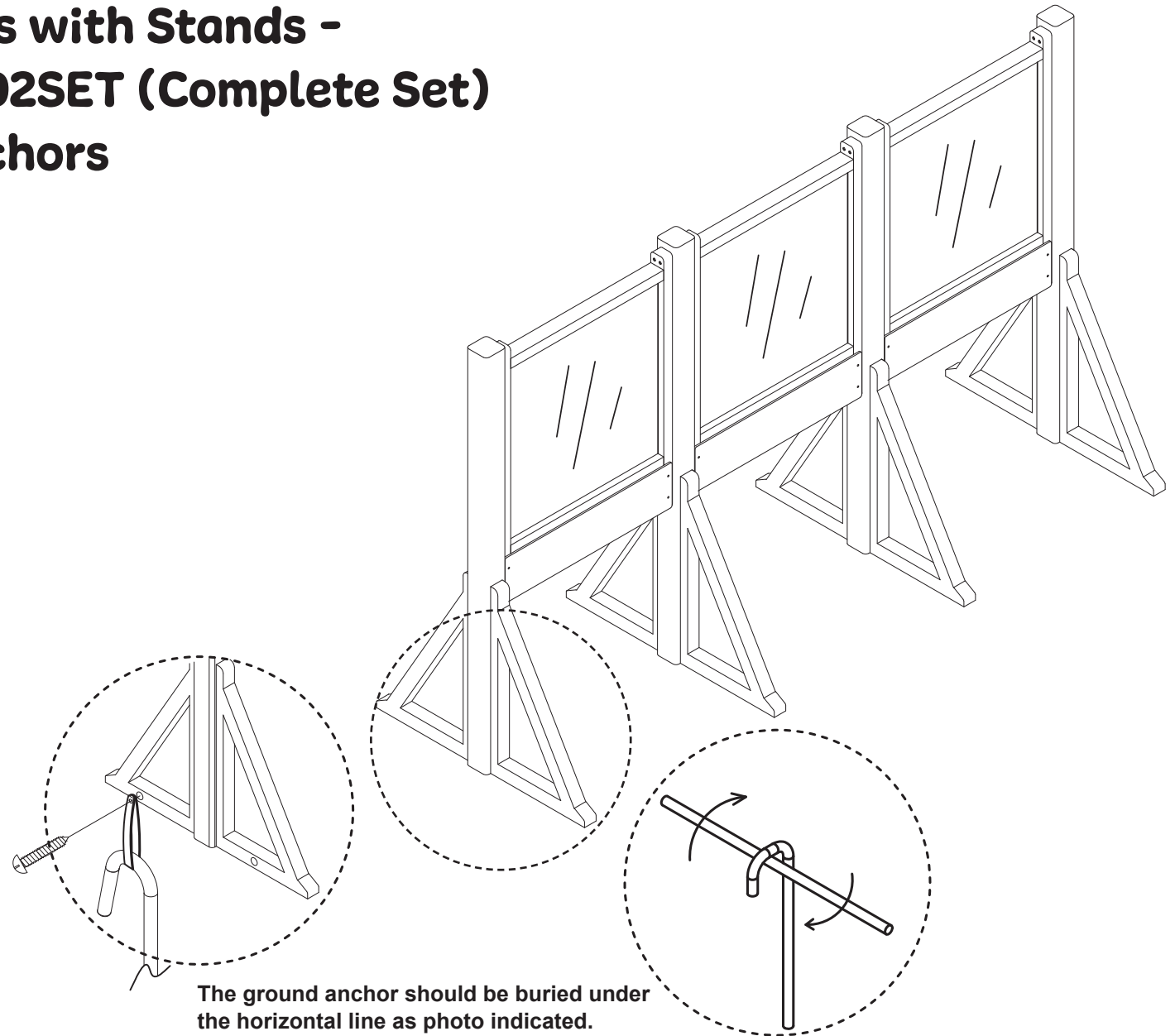

Outdoor Vision Boards with Stands - Item Code: HW1-SZH02SET (Complete Set)

INSPECTION INFORMATION				
Inspection cycle	Inspection Project	YES/NO	Solution	Signature
Daily Inspection on Items	Check screws, bolts and fasteners are tightened.			
	Installed on a flat surface and no hazards are present.			
	Equipment is free of dirt and moisture.			
	Hook and loop attachments are securely fastened.			
	Check for a signs of damage and wear.			
Monthly Inspection on Items (Except for Daily Inspection on Items)	Check screws are free of rust and damage.			
	Check parts are securely connected.			
	Check compliance labels are intact.			
	Check if the protective surfacing meet safety standards			
Annual Inspection on Items (Except for Daily and Monthly Inspection on Items)	Check there is no extensive corrosion and replace if required.			
	Check for cracking or connecting part deterioration. Replace if required.			
	Check there is no excessive discolouration of components.			
	Check screws and connectors are in working order and not damaged or deteriorated.			
	Check compliance labels are legible.			
	Check the play area under the equipment is safe and level.			